

evolve system

Planning Guide

Application	Panel Height	Panel Type	Modules	Extension Modules <small>(6, 12, 18 & 24H)</small>
Workstations	30"	Monolithic	Fabric	Yes
Benching	42"	Segmented	Glass	No
Partition	48"		Slat	
	54"	Laminate Gallery Panel	Metal	Total Panel Height
	66"	42" 48"	Laminate	<small>(Panels must be specified at least 6"H lower than the ceiling)</small>
		Frameless Glass <small>(Channel Set)</small>	Whiteboard	
		Clear 6"	Open	
		Frosted 9"	Air Flow	
				COM Fabric
				<small>(Contact customer care for approval)</small>

Electric	Infeed	Duplexes <small>(amount per workstation)</small>	Color <small>(Upcharges apply for white and sand)</small>
Yes	Base		Black
No	Ceiling		White
			Sand
	Ceiling Height		

Special Electric	Standard Electric — 8-wire, 4-circuit, 2+2 — additional wiring schematics are available, contact customer care
Chicago	
New York	
CA - Title 24	

Laminate	Surface Depth	Height Adjustable Tables
Thermally Fused 1" thick, 3mm edge	18"	OTG
High Pressure, 1-1/16" or 1-7/16" thick, 3mm edge	24"	Foli
Special Laminate or Wood Veneer, contact customer care	30"	FreeFit

Base Storage	Overhead Storage	Center Mount Overhead
Pedestal/Lateral File/Tower	Metal Only	To access from both sides in a back-to-back scenario
Metal	Flat Front	Open <small>(Laminate)</small>
Laminate*	Full Pull	Sliding Glass Doors <small>(Laminate/Metal)</small>
	Sliding Glass	
	Easy Up <small>(Soft Open, White Acrylic Front)</small>	
	Shelf	

*Evolve now has NEW Laminate Storage Options. See Back of Planning Guide. Also consider Global Zira, Princeton, Bridges II and Side Bar.

Accessories	Load Bar Options	Seating
Single Monitor Arm	Binder Bin	Task
Double Monitor Arm	Flip Sorter	Guest
Overhead Task Lights	Slant Sorter	
Freestanding Task Light	Letter Tray	
Keyboard Tray	Letter Tray (Legal)	
Load Bar	Media Bin	*Global recommends a specification check for all product applications. These can be sent through www.evolvefurnituregroup.com under "eforms" then "specification request"
Whiteboard	Utility Tray	
Tackboard	Mailbox	
Coat Hook	Telephone Holder	
Name Plate		

Panels

Panel Thickness — 2 7/8"

Stack over 14 feet high



Extension Heights

6"
12"
18"
24"

Metal Top Cap

Panel Widths — 18" - 60"

Monolithic or Segmented

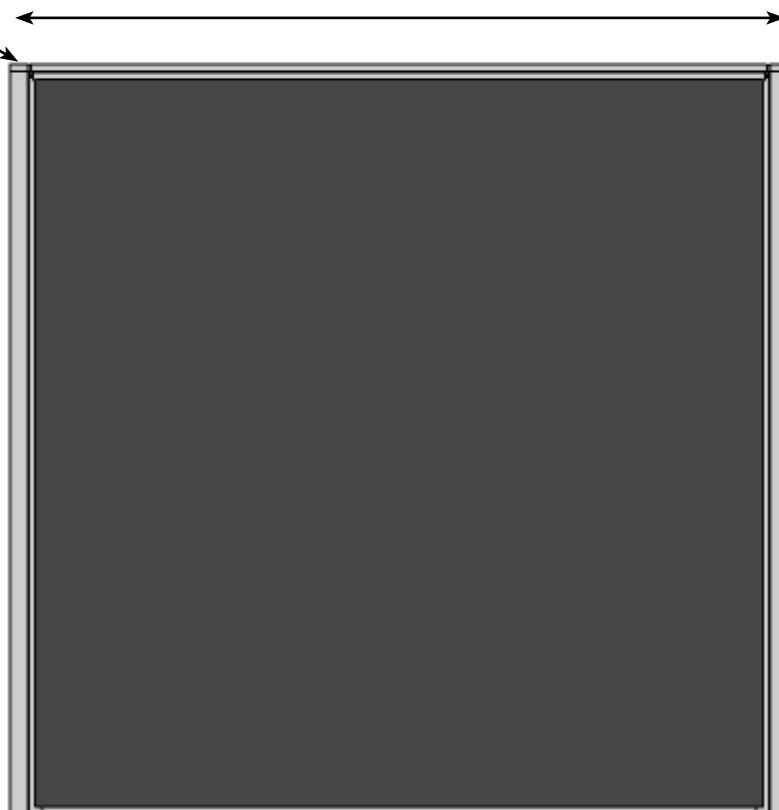

Panel Heights

30"
42"
48"
54"
66"

Metal Raceway

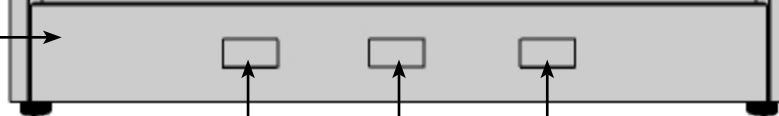

Knockouts — Base and Beltline Raceway

18"W Panels — No Knockouts
24"W Panels — One Knockout
30"W Panels — Two Knockouts
36"W Panels — Three Knockouts
(center knockout for data only)

Leveling Glides
2.5" Max

Panels

Acoustic Rating — .65 NRC 23 STC

Cabling

The beltline raceway cavity can accommodate 65 Category 5 data cables or 54 Category 5 data cables when the power distribution housings are present.

Cabling

The base raceway cavity can accommodate 140 Category 5 data cables or 48 Category 5 data cables when the power distribution housings are present.

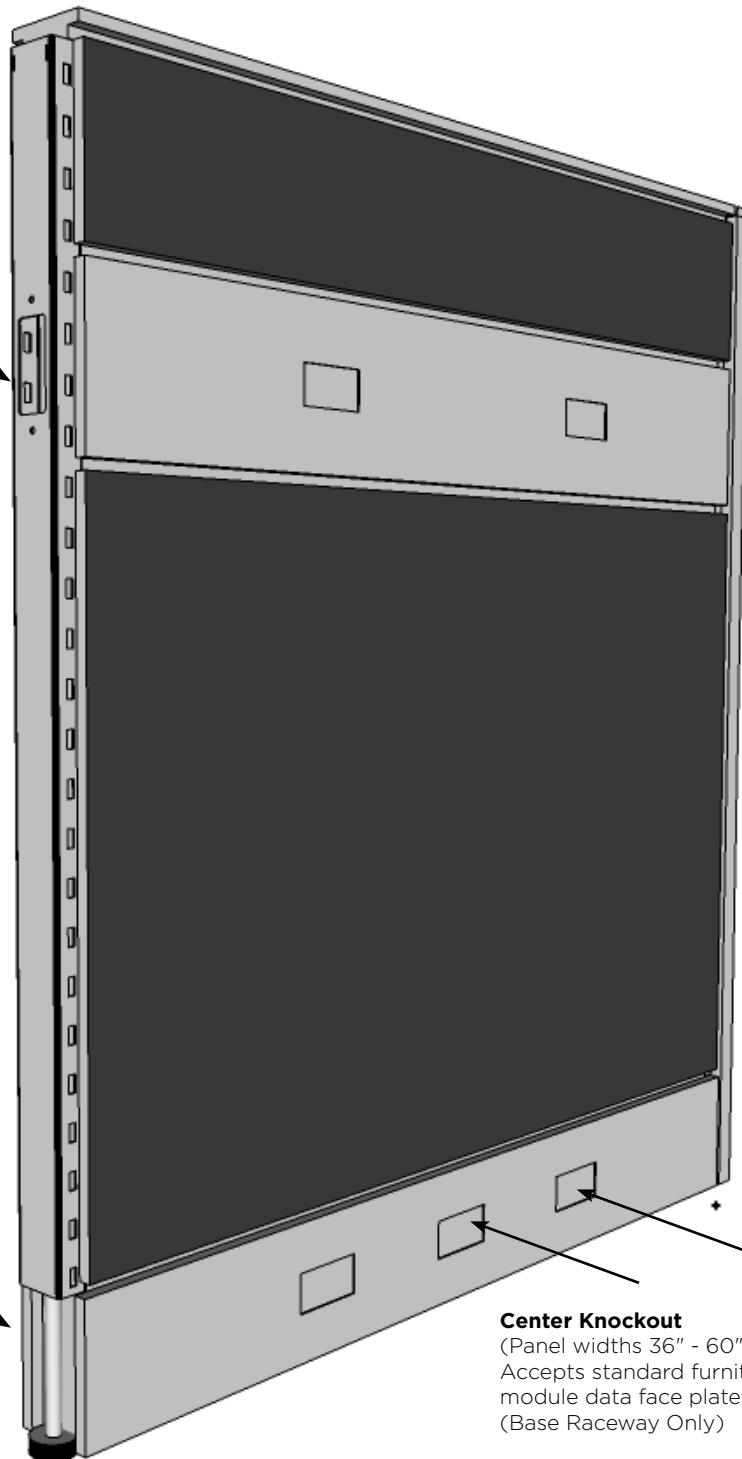

Knockout
1.345" x 2.680

Center Knockout
(Panel widths 36" - 60")
Accepts standard furniture
module data face plates
(Base Raceway Only)

Panels

Heights

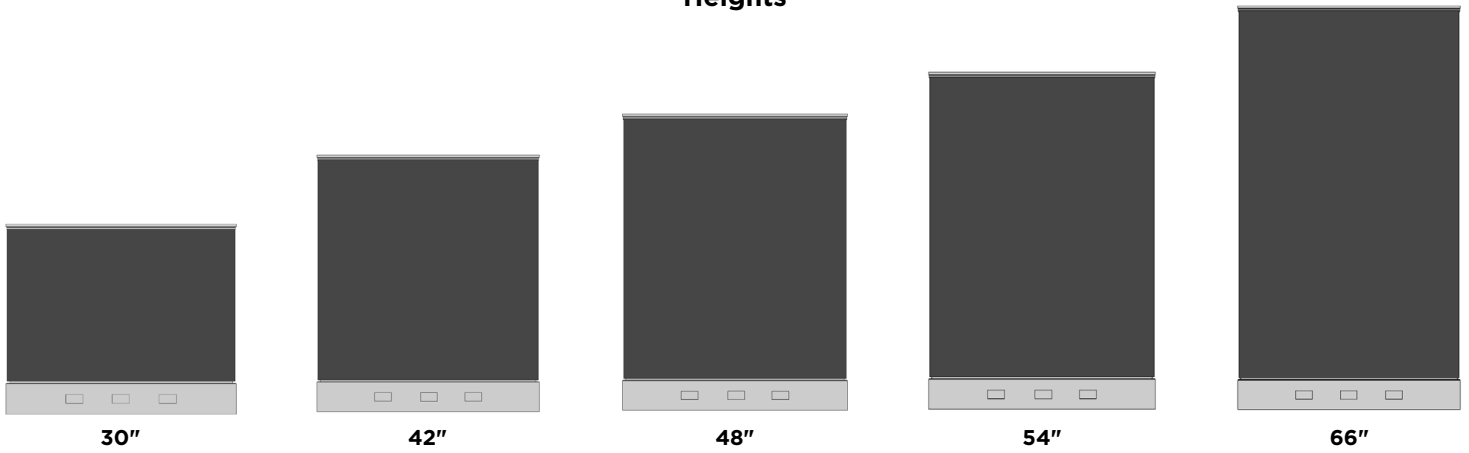

Styles

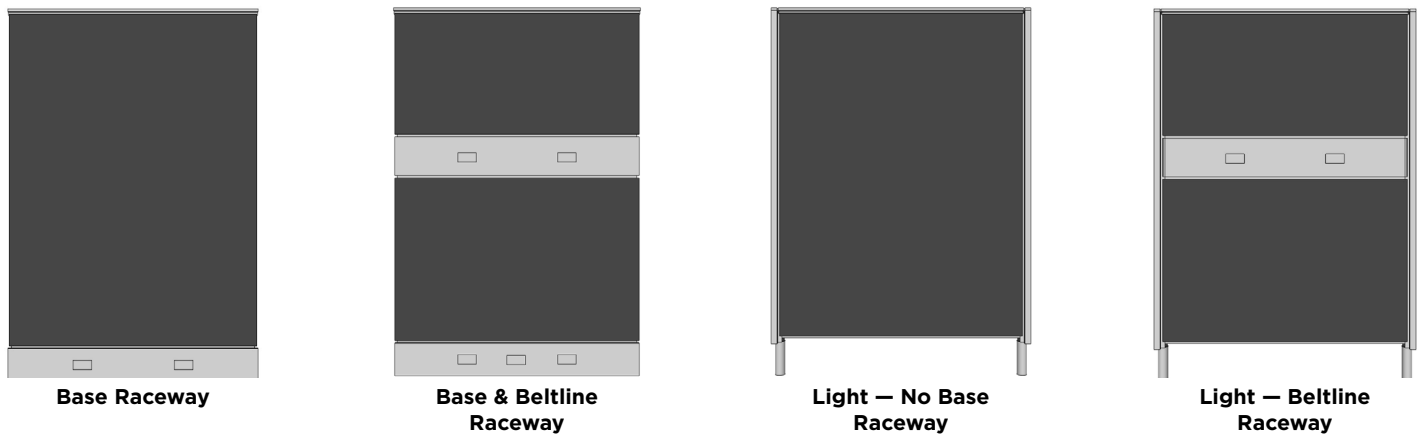

Modules

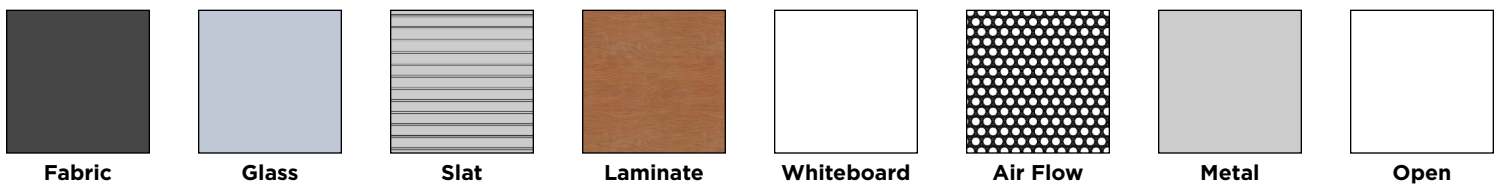

Panels

Base Raceway Panels

Available in "Light" version that does not contain a raceway



Monolithic
30, 42, 48, 54, 66

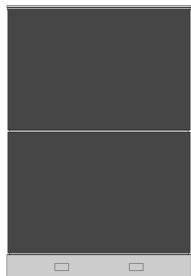

Segmented
42, 54, 66

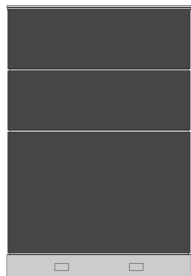

Segmented Premium
54, 66

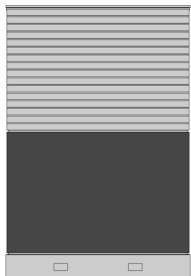

Slat Wall
42, 54, 66



Write Board
54, 66

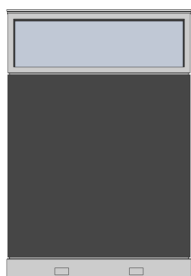

12" Glazed Monolithic
48, 54, 66



12" Glazed Premium
54, 66

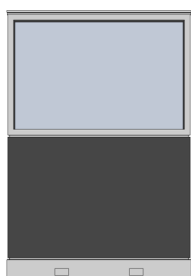

Partly Glazed
66

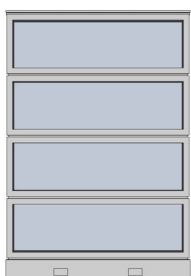

Premium Glazed
42, 54, 66

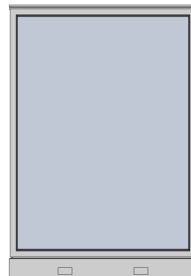

Fully Glazed
42, 48, 54, 66

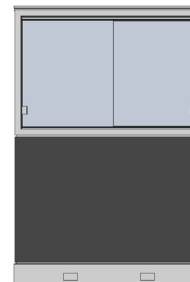

Sliding Glass
42, 54, 66

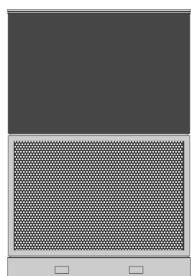

Air Flow
30, 42, 54, 66

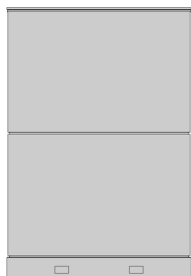

Metal
30, 42, 54, 66

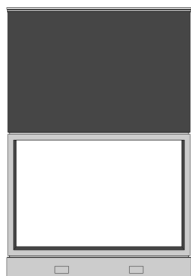

Open Bottom
30, 42, 54, 66

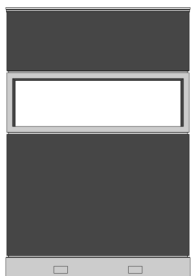

Open Module
42, 54, 66

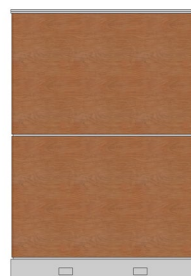

Laminate
42, 54, 66

Beltline Raceway Panels

Available in "Light" version that does not contain a raceway

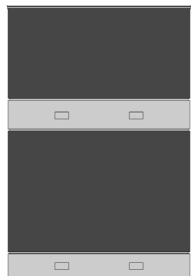

Monolithic Beltline
42, 54, 66

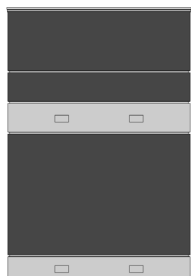

Segmented Beltline
42, 54, 66



Glazed Beltline
42, 54, 66

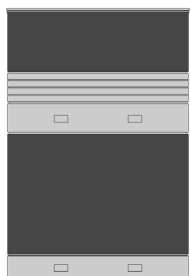

Slat Wall Beltline
42, 54, 66

Panels

1" Laminate Panels

Auto Connectors is not programmed for the 1" Laminate Panels

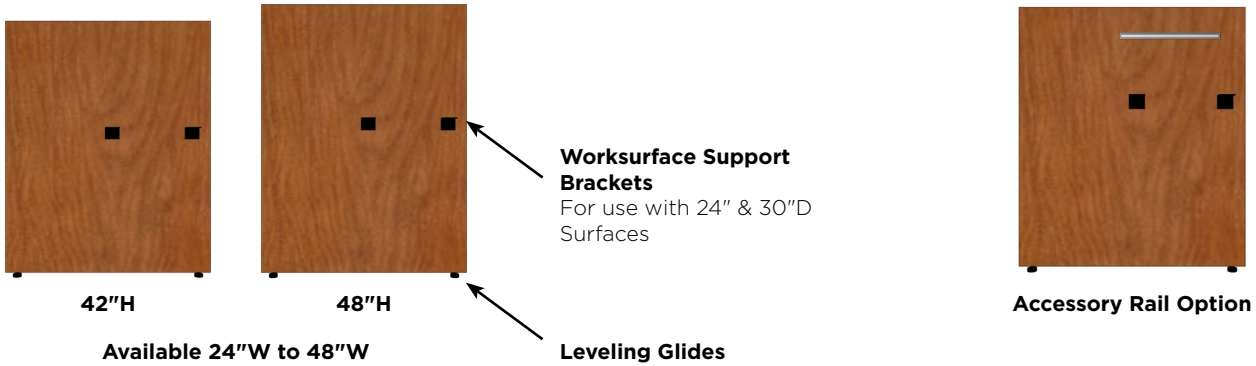

Specification

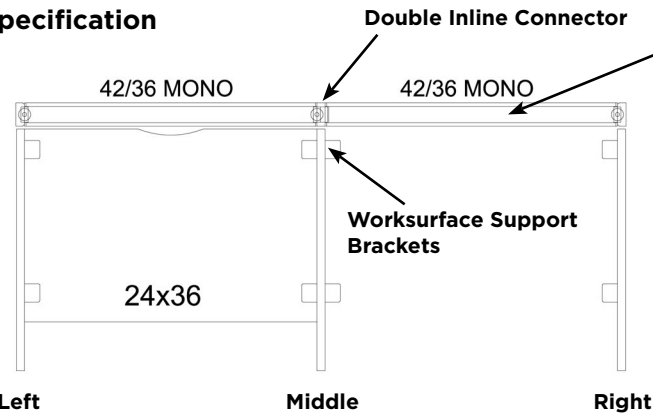

Specify Top Trim 1" Longer than Panel Width

Install Note:

When installing a pedestal next to the gallery panel, the brackets that connect the 1" laminate panel to the worksurface will interfere with the pedestal. It is best to remove these brackets and attach the pedestal to the worksurface and 1" laminate panel in the field.

The Double Inline Connector must be specified for each 'Middle' laminate panel

Top trim is included standard on Evolve Panels. In this application the "double inline" connector creates an additional 1" of space between the panel (this allows for the specification of standard worksurface widths). The top trim to add the additional 1" is specified separate.



Extension Modules



6"



12"



18"

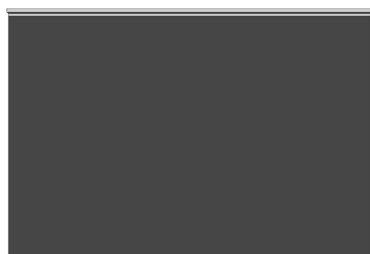

24"

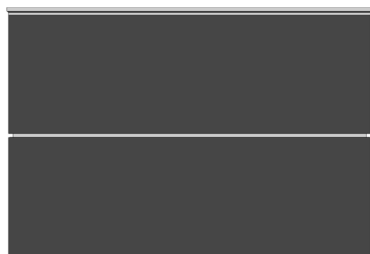

24" Premium (Segmented)

Extension modules are available in multiple sizes to achieve partitions over 14' high.

Specify "Extension Module Extension Connectors" to coordinate with the height of each module and the style of base connector. (Example: End-of-Run, 2-Way, etc.)

Installation Note: 6"H modules must be installed at the top only.

Privacy Glass



6"H, 9"H, 12"H Privacy Glass
Channel Mount (single extrusion)
24" - 72"W

Extension Module Materials



Fabric



Glass

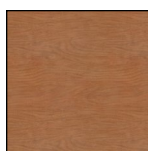

Laminate

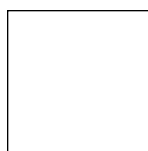

Whiteboard

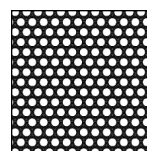

Air Flow

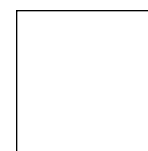

Open

Connectors



Inline



End of Run



2-Way

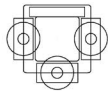

3-Way

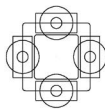

4-Way



1-Way

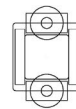

Inline Post

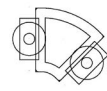

45 Degree



60 Degree



Inline Connector

Inline and Two Single Clamps

Variable Height Option Available
Step Down Trim & Notched Top Trim (for lower panel specified separate)

*Contains the slots that accept Surface Hardware, Overheads, Etc.

Specify in between two panels in a straight run.

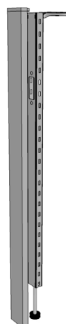
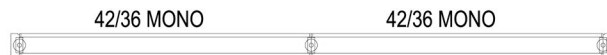

End of Run (also Wall Start)

Inline, Single Clamp, End of Run Trim

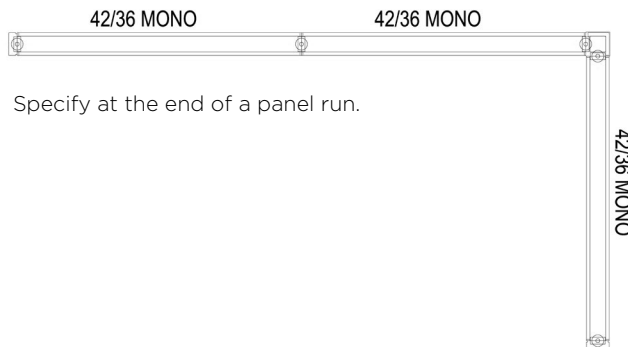

Specify at the end of a panel run.



Corner Post

1, 2, 3, & 4-Way, Inline Post
Post, Inline(s), Single Clamp(s), Flat Trim(s)

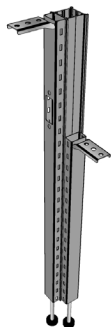
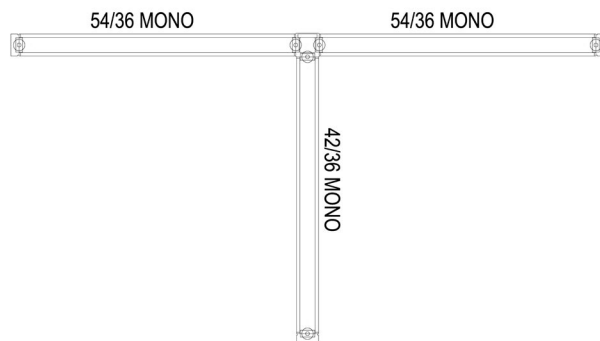

Variable Height Corner Post

1, 2, 3, & 4-Way, Inline Post
Post, Inline(s), Single Clamp(s)

Corner posts contain an inline and single clamp per the amount of directions that the connection will make.
(Example: 2-Way = Post, 2 Inlines, 2 Single Clamps, 2 Flat Trims)

Connectors

Base Connectors

- 2-Way Connector**
Post, 2 Inlines, 2 Flat Trims, Top Cap
- Inline Connector**
1 Inline
- End of Run Connector**
1 Inline, 1 End of Run Trim

Trims (specified separate)

- Step Down Trim**
End of Run Trim
 - Notched Top Trim**
- *Optional Continuous Top Trim**
Up To 96" w (Specified Separate)

Extension Connectors

- 2-Way Extension Connector**
Extension Post, 2 Extension Inlines,
2 Extension Flat Trims
- Inline Extension Connector**
Extension Inline
- End of Run Extension Connector**
1 Extension Inline, 1 Extension End of
Run Trim

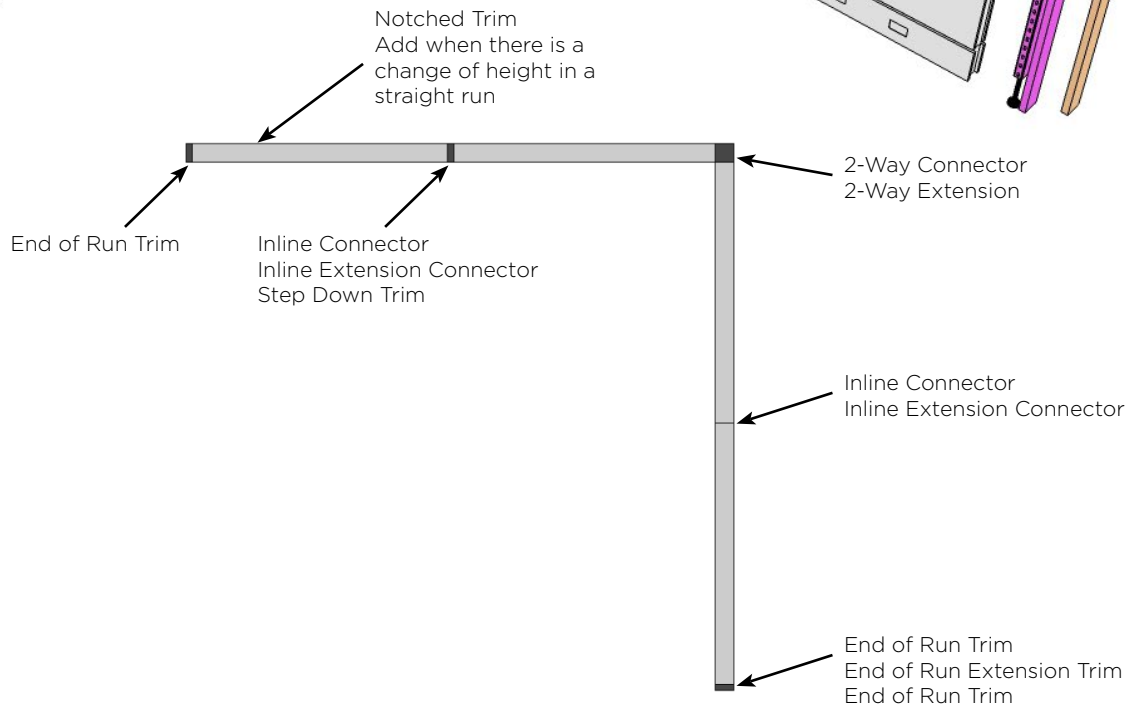
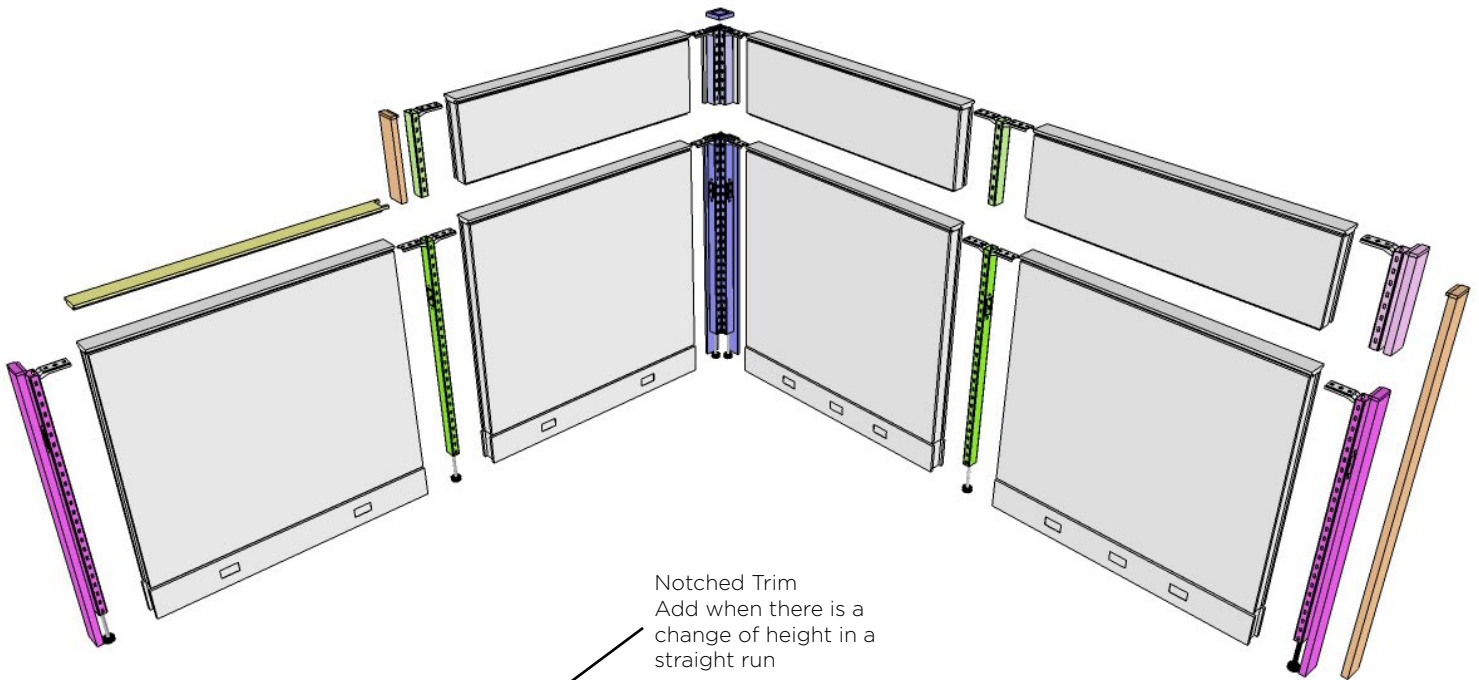

Connectors

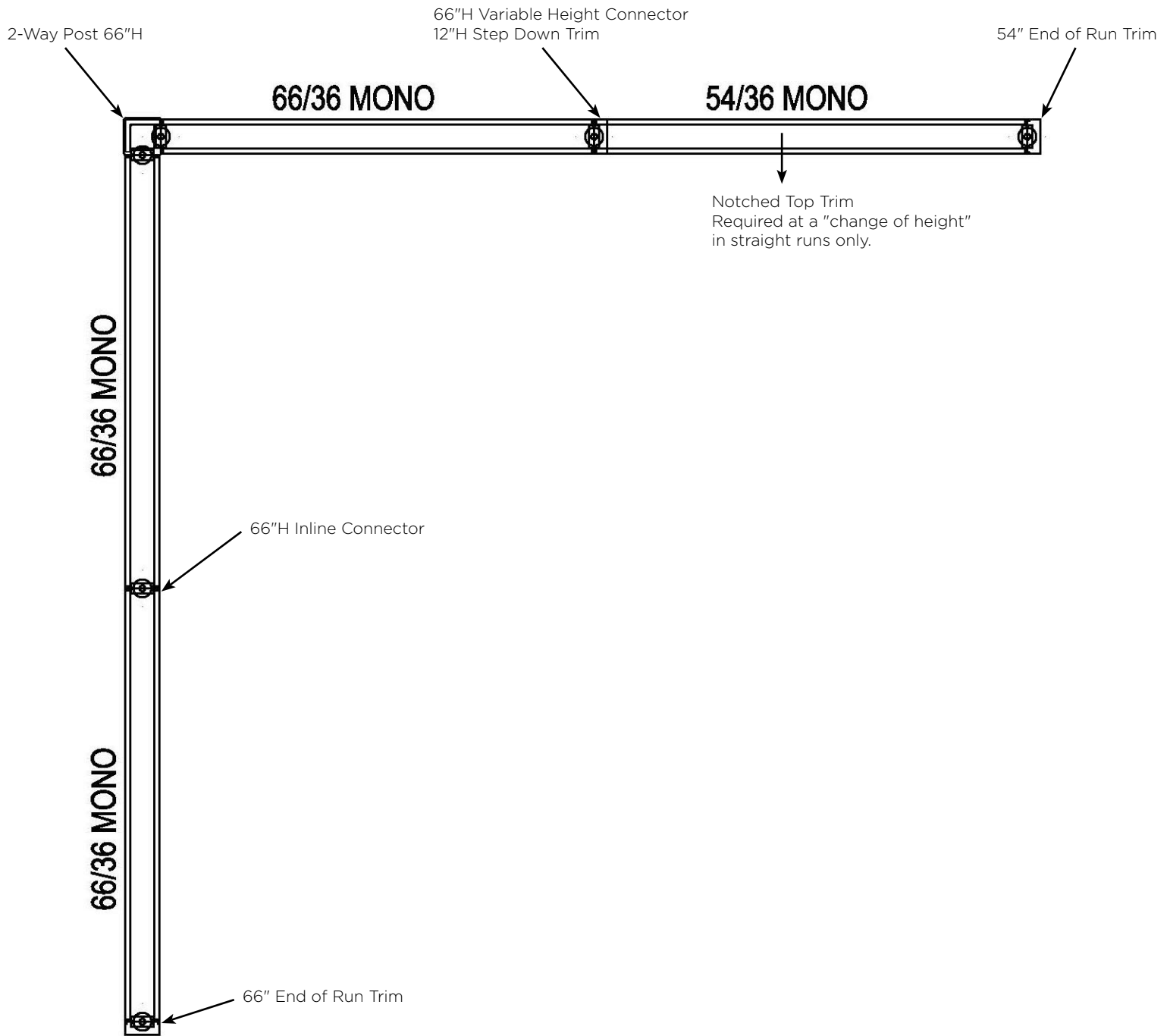

Variable Height Connectors

The Variable Height Connector will start with a post height that matches the tallest panel. Specify variable height connector inlines starting with position "1" and continue clockwise. Auto Hardware is programmed in CAP and Giza.

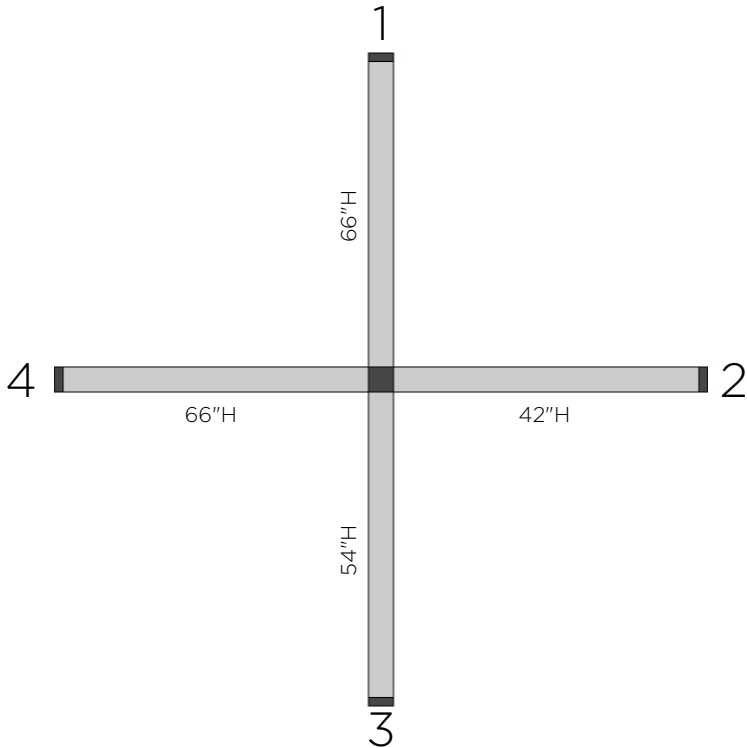
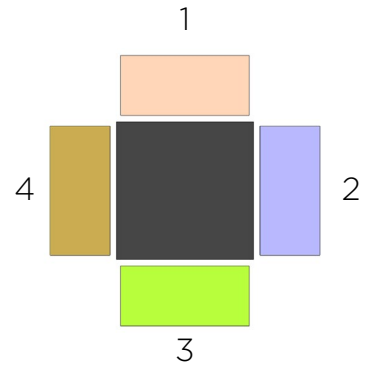
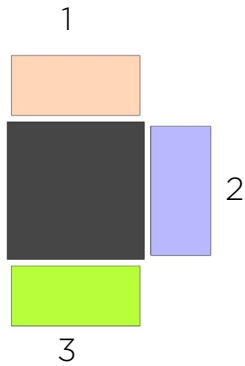
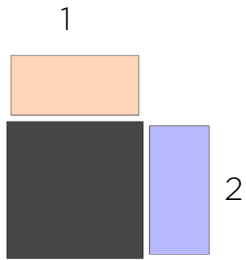

Example

4-Way – Variable Height Connector
 Match the Post Height of the Tallest Panel (66"H)
 Select Position 1 (66"H)
 Select Position 2 (42"H)
 Select the 3rd and 4th Positions (54" - 66"H)
EVPVPA466-6456 (Product Code)

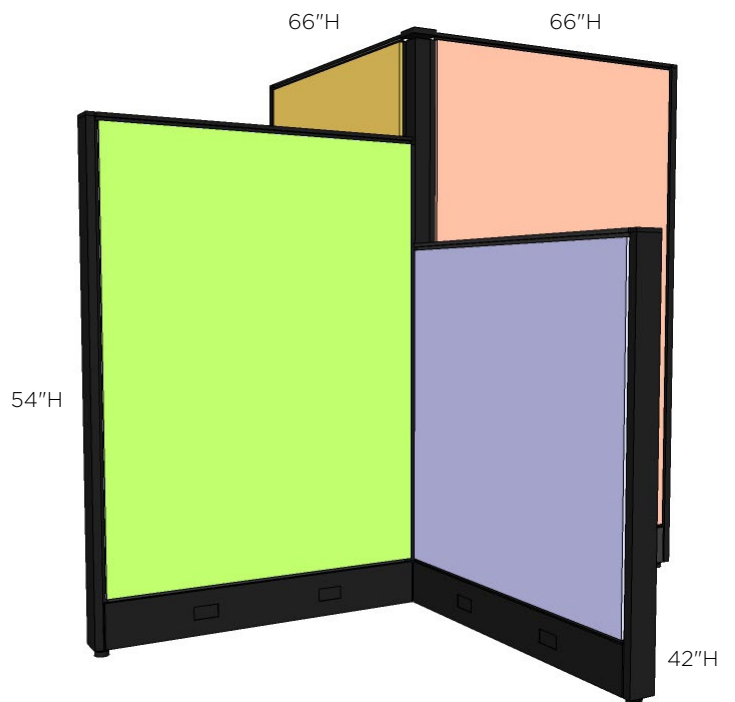

Connectors — Black Reveal

Evolve offers two different paint options for panel interior frames and connectors.

Paint with Matching Horizontal Reveals

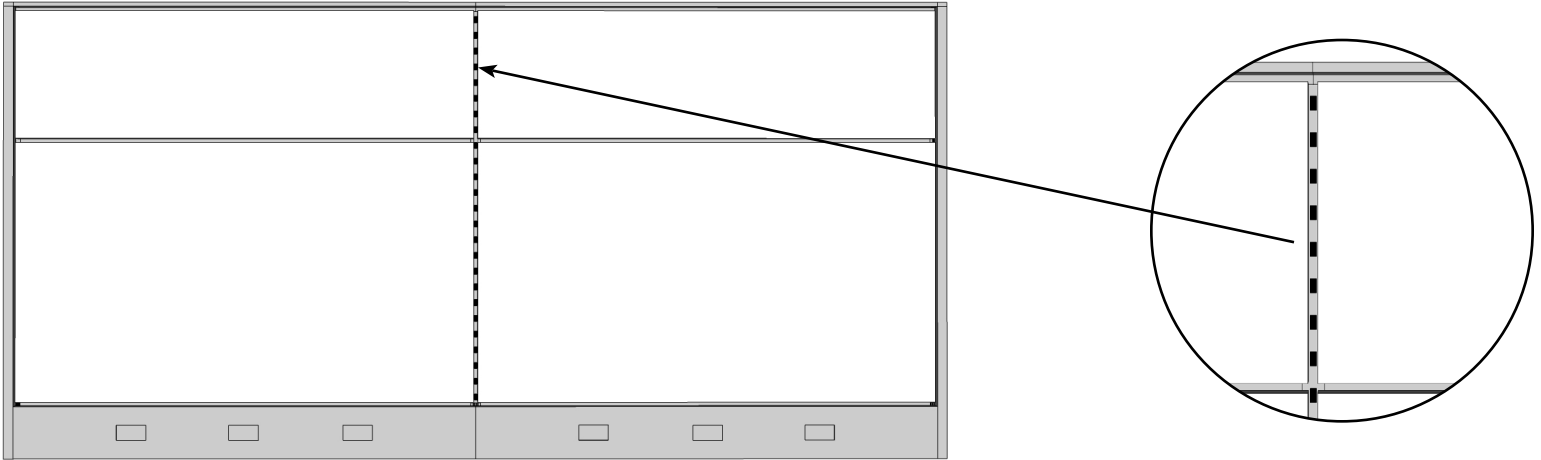

Paint with Black Horizontal Reveals

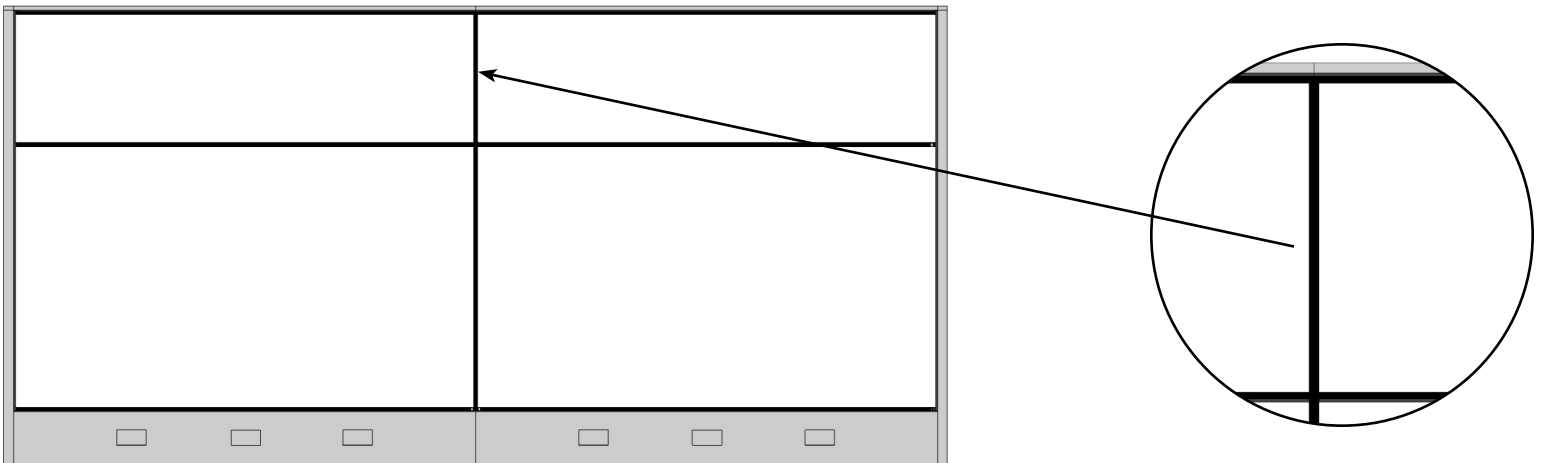

- The Black Horizontal Reveal option will create a cleaner aesthetic by minimizing the appearance of the slots on lighter color panel frames
- Models that have additional trims will be listed with the option for Black Reveal. Inline Connectors, without additional trims, should be selected with Black paint only.
- For add-on orders for existing installations with Matching Horizontal Reveals, please select this option.
- For new installations, we recommend selecting the Black Horizontal Reveal option.
- When specifying all inline and variable inline connectors must be black.

Electric – Wiring Schematic

Standard Evolve Electric

4-2-2 Wiring System

8-Wire Shared Neutral

2+2 (2 Dedicated, 2 Utility Circuits)

For existing projects & reconfigurations: orders placed previous to April 1, 2005 the electric is 8-wire 3+1.

Contact Customer Care for additional information

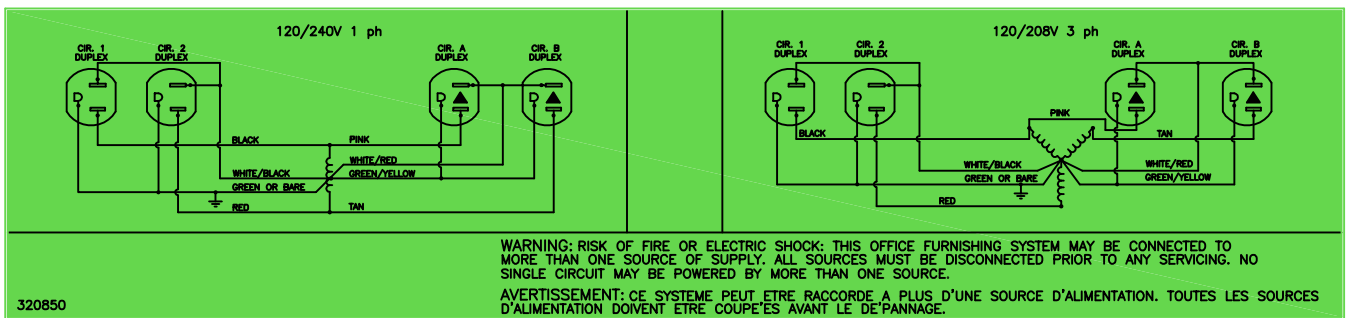
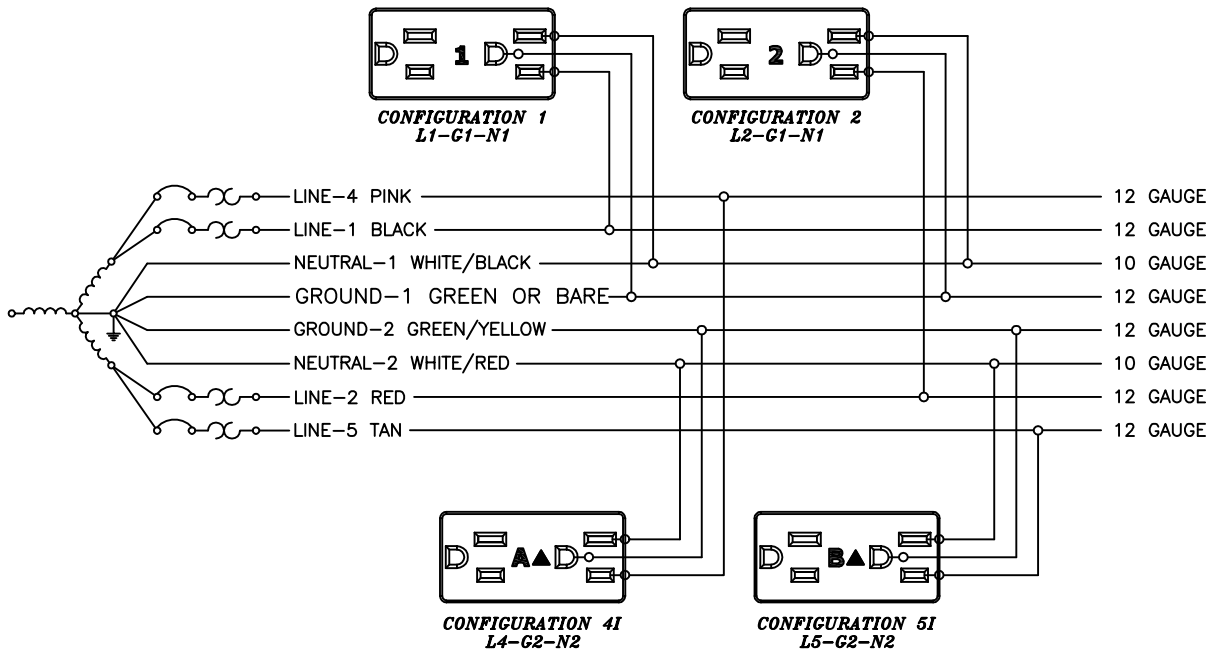

Electric

Basefeed

Must be specified to enter at an opening on the Power Distribution Housing (will take the place of a duplex receptacle).

* When planning against a wall, allow 3" for clearance.

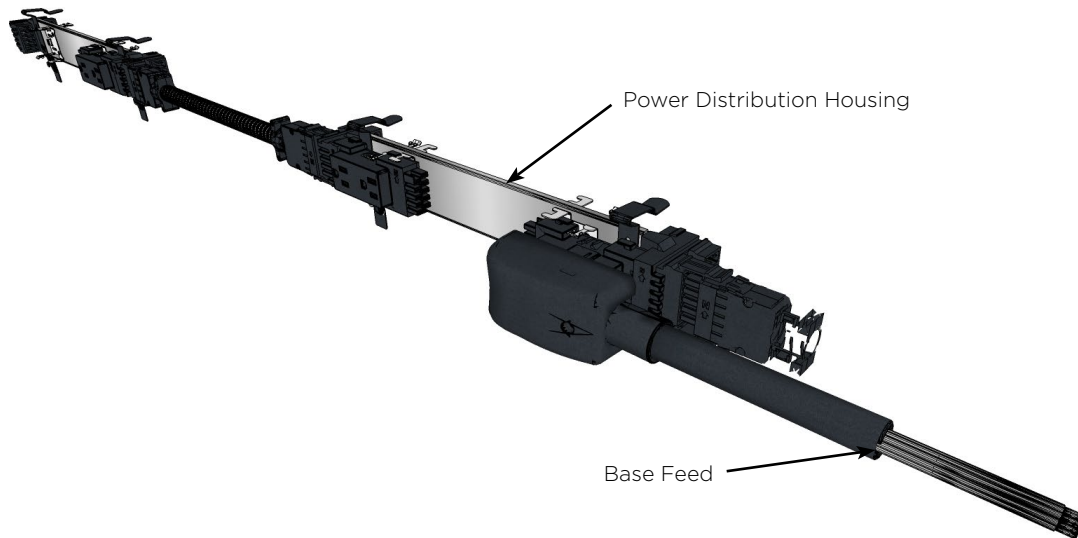

Ceiling Feed

Must be specified to enter through a post connection, along with a Post Extension (specified separate)

Must plug into a Power Distribution Housing via an adjacent panel

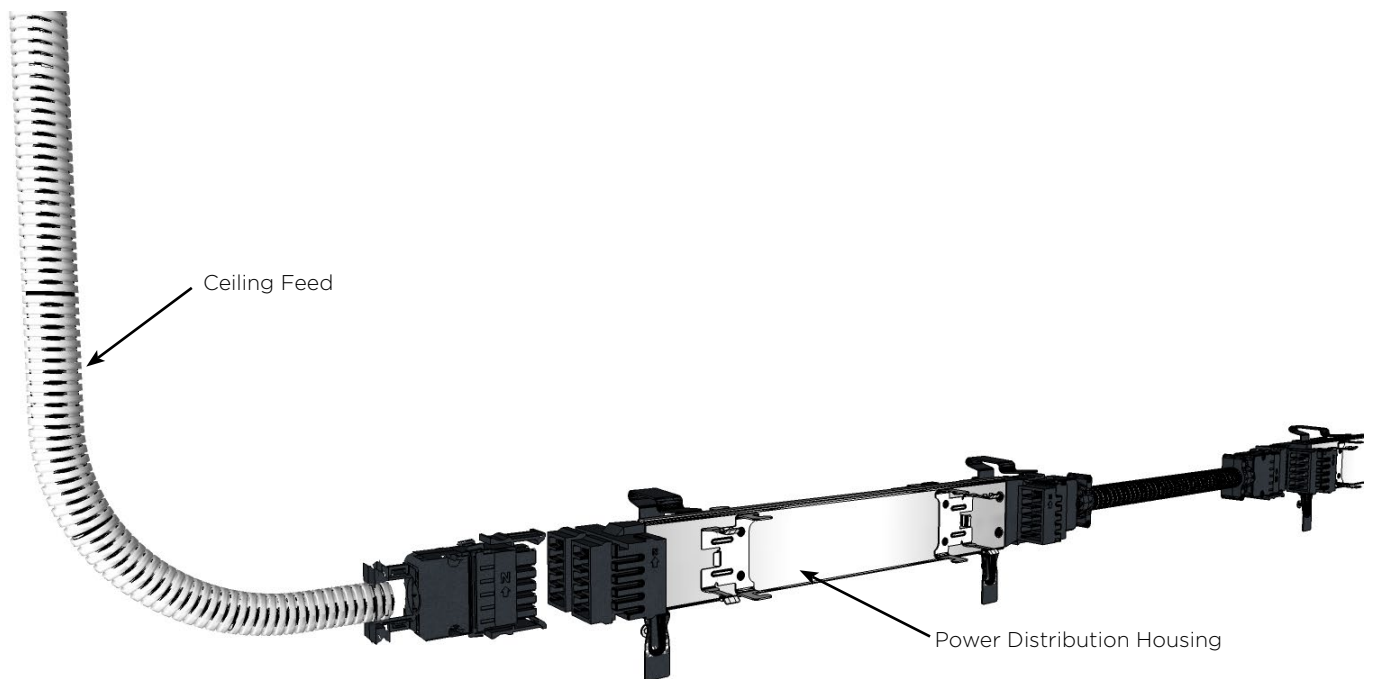

Electric – Base Raceway

Ceiling Feed

A ceiling infeed must enter at a "post connection". An extension post must be specified separate.
 Cabling Capacity - Post Extension without electric: 45 cables; with electric: 25 cables

For a 3-way connection specify (2) 20"
 For a 4-way connection specify (3) 20"

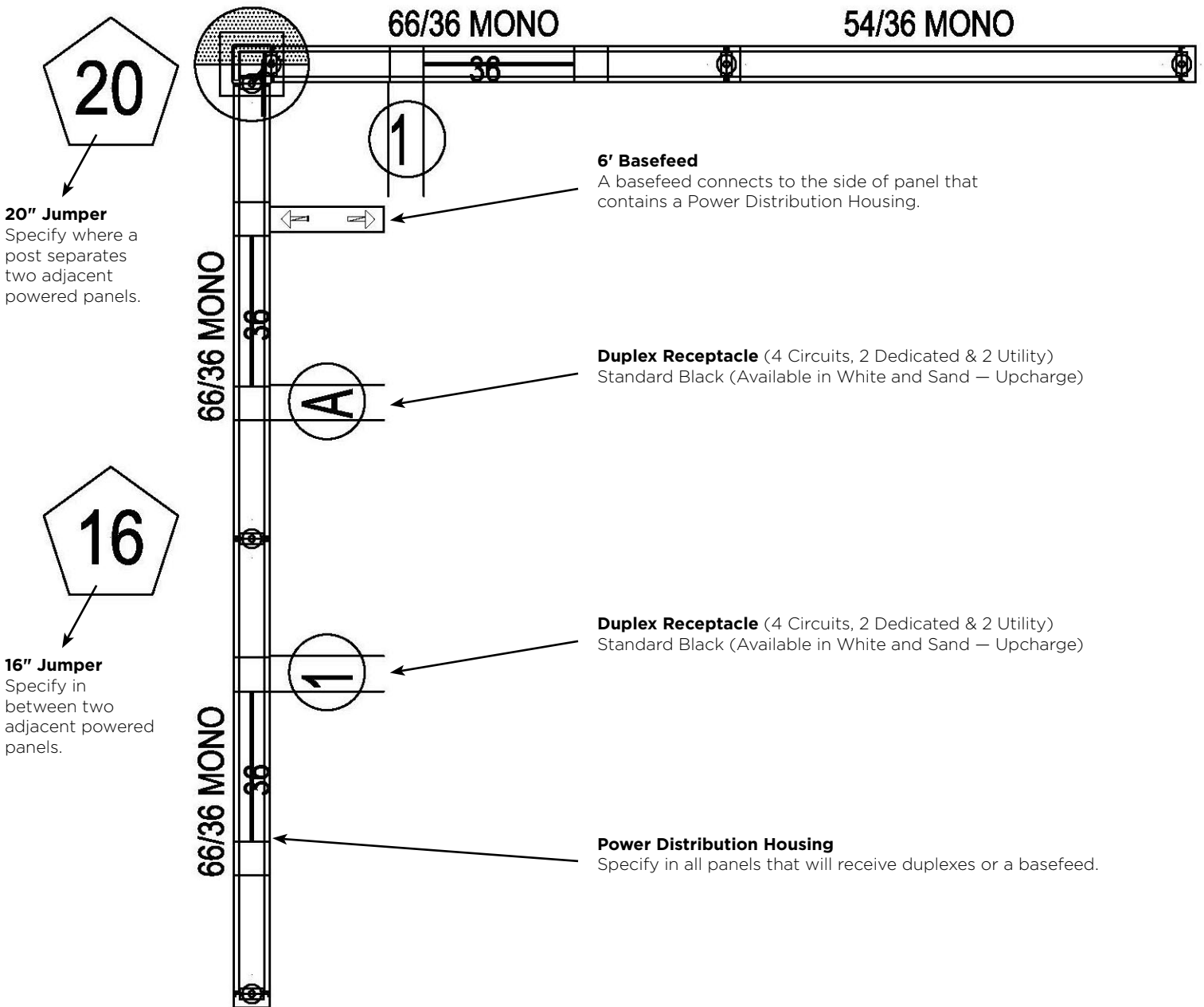

Specifying Duplexes

32 Duplexes per Infeed (utilizing 4 circuits) or 8 Workstations per Infeed (maximum of 4 duplexes per station, utilizing all 4 circuits)

Electric – Beltline

Benching with Beltline – Plan View

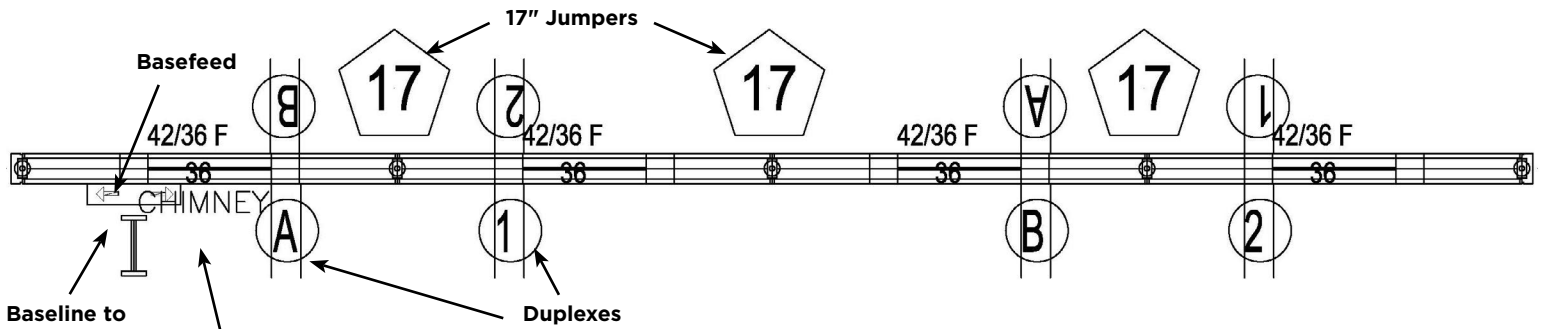

Baseline to Beltline Jumper

Specify in the Chimney Panel to connect the Power Distribution Housing in the Base to the Belt.

Chimney Panel

Specify a Chimney Panel to jump electric from the base raceway to the beltline.

17" Jumper

Specify in between Power Distribution Housings (if running the power at the base and belt; two jumps will be required in between each panel)

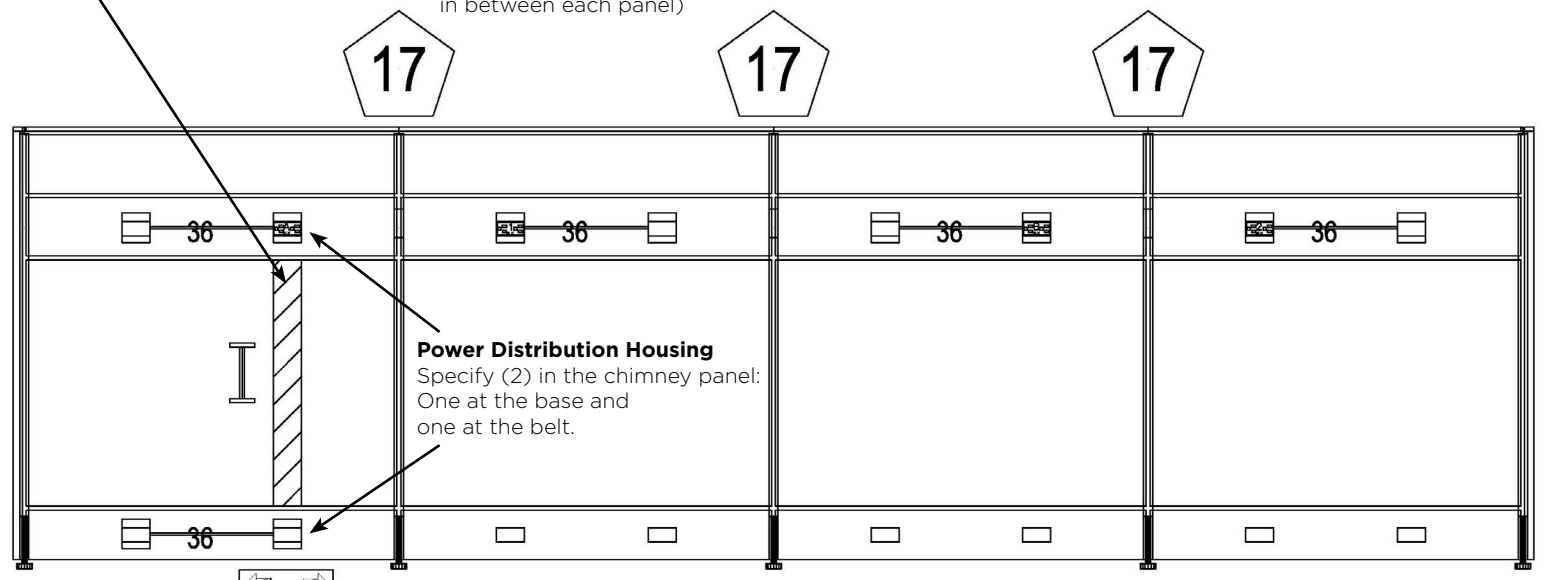

Power Distribution Housing

Specify (2) in the chimney panel: One at the base and one at the belt.

Basefeed

Ceiling Infeed

Specify a "One Way" Post at the end of the run (then specify the Ceiling Infeed and Post Extension)

Benching with Beltline – Front View

Electric — Spanning Panels

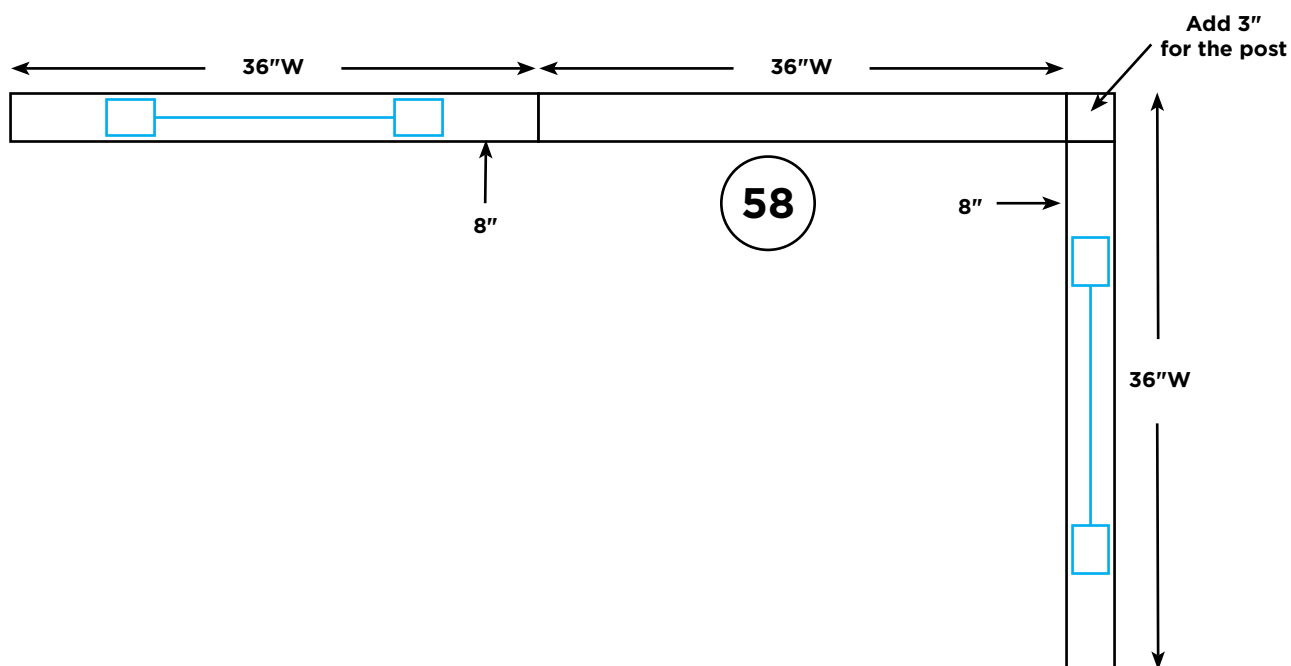
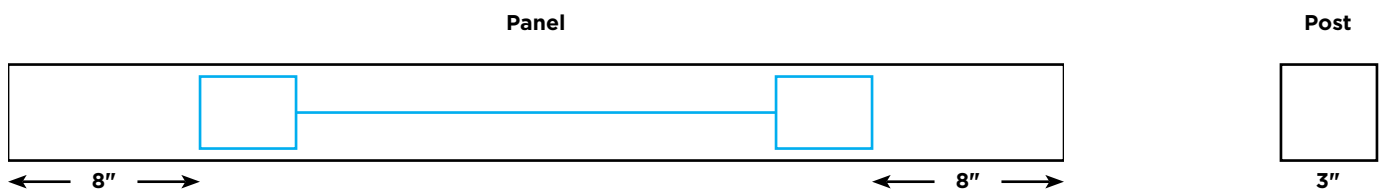

$$8" + 36" + 3" + 8" = 55"$$

Pass-Thru Cable — Male/Male

Specify the length of cable to either match the calculated number or select the next size up.
(Example: 58" for the sample layout above)

Electric – Special Codes

Chicago

Specify panels without the addition of power distribution housing and specify junction boxes where receptacles will be installed.

Junction boxes can not be installed "back to back".

36"W panels (or wider) do contain a center knock out. The center knockout can be used for a junction box (one side only).

New York City

Specify panels with power distribution housings, duplexes and jumpers.

The NY Basefeed must be specified in an open raceway of a panel 30" or wider. The basefeed can only run in one direction. Jumper cables can not be used to run with the NY Basefeed in another direction. Cabling capacity is diminished in the panel that contains the NY Basefeed.

California, Title 24

Specify panels with power distribution housings, jumpers and infeed.

Controlled circuit duplexes are in the specification tools for all (4) circuits.

*Electrical contractor must install proper control devices (occupancy sensor) that will turn off power to controlled circuit duplexes.

Worksurfaces

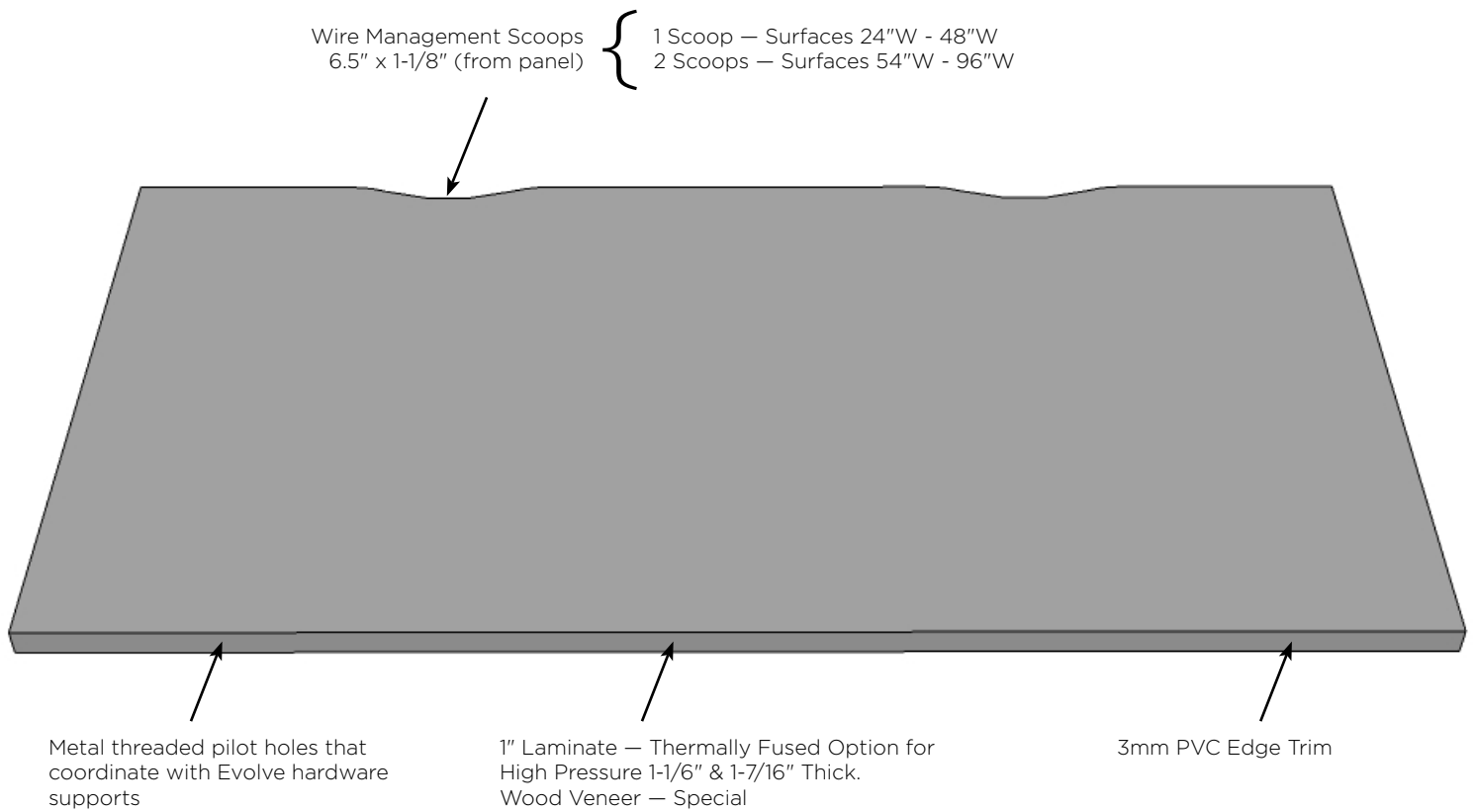

Worksurface depths are nominal and allow a 3/8" gap between the back of the worksurface to the panel for wire management.

This guide contains a product map of standard shapes

Laminate Options

www.evolvefurnituregroup.com/laminates.html

Request a Special Worksurface

www.evolvefurnituregroup.com/specrequest/sq.aspx

For existing projects and reconfigurations: Orders placed previous to March 1, 2014 the laminate is 1-1/8" thick. This option is no longer available.

Hardware

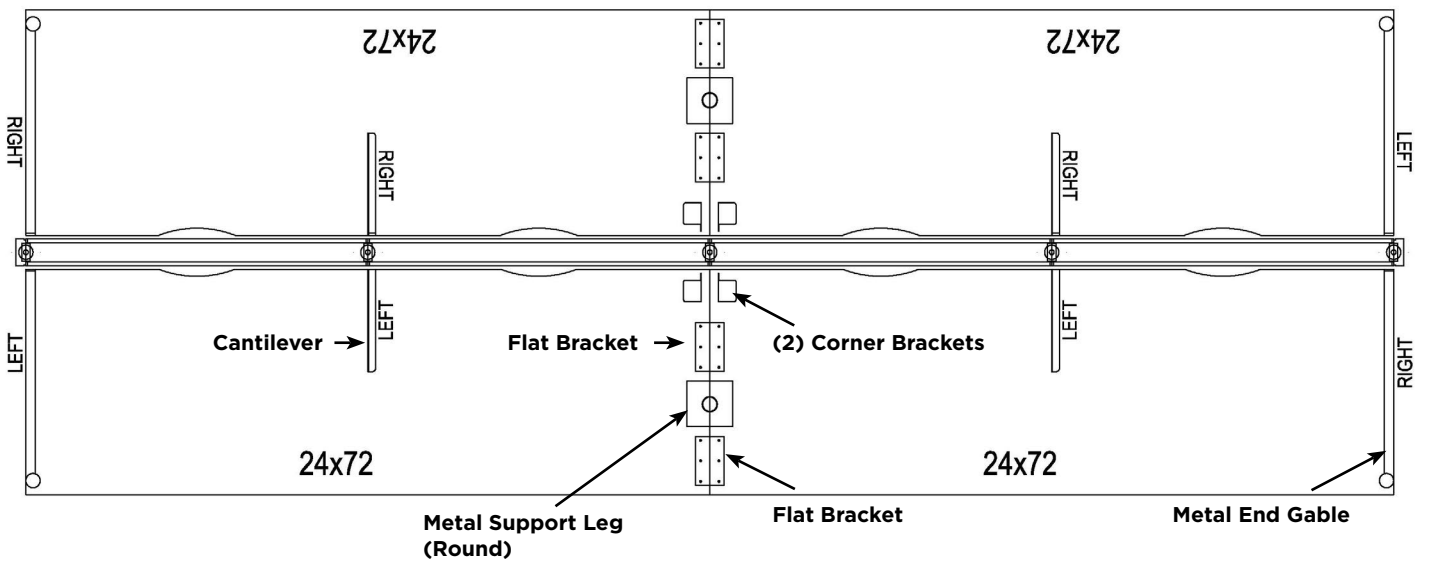
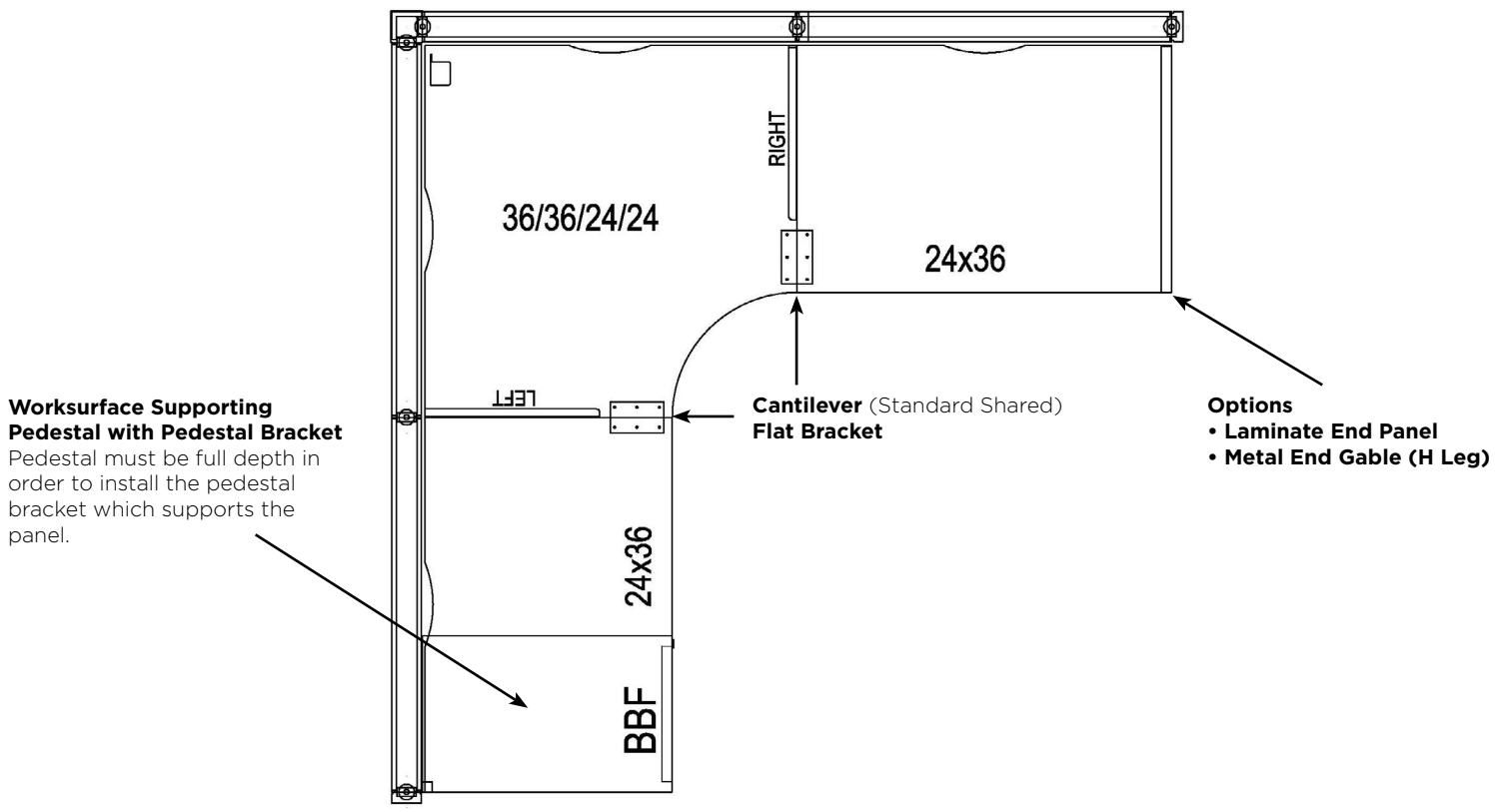

Worksurfaces

←→ Indicates grain direction

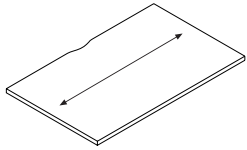

EVWS

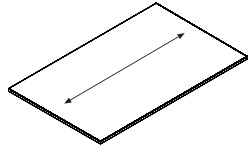

EVWSNS

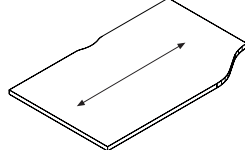

EVWVR

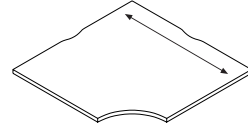

EVWCC

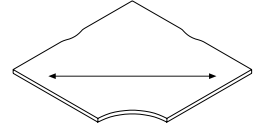

EVWCCxxxWG

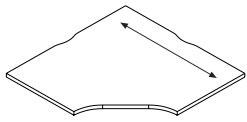

EVWCK

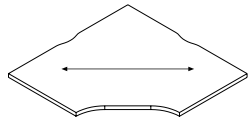

EVWCKxxxWG

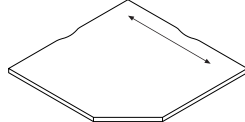

EVWCF

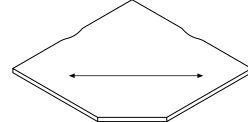

EVWCFxxxWG

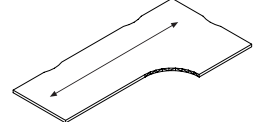

EVWCE

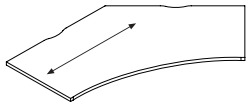

EVWC4C

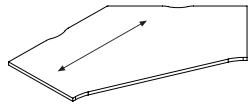

EVWC4K

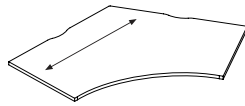

EVWC6C

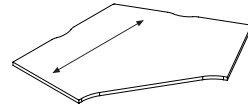

EVWC6K

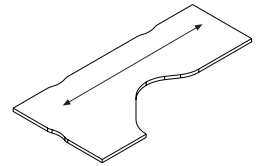

EVWL

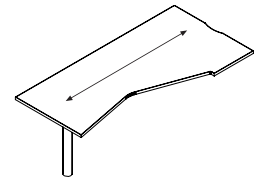

EVWHL

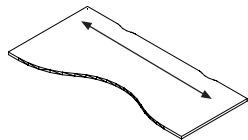

EVWBTL/R

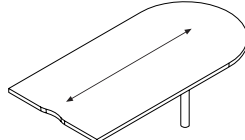

EVWD

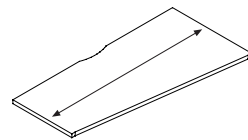

EVWSWL/R

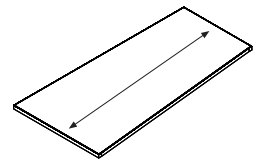

EVWSENSL/R

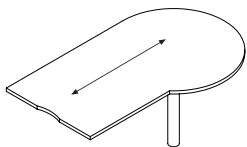

EVWP

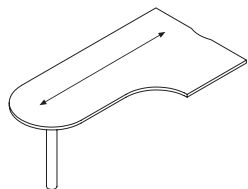

EVWPL/R

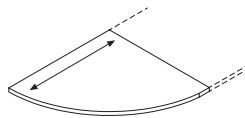

EVWQR/EVRQRC

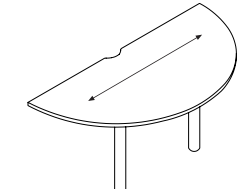

EVWR

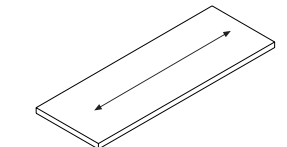

EVWT, EVWTV, EVWTW,
EVWTEV, EVWTDV,
EVWTTD

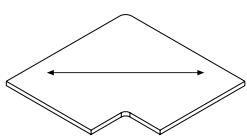

EVWTCLxxxWG

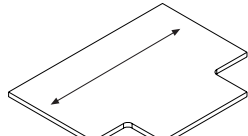

EVWTC

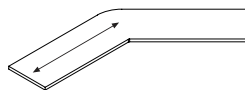

EVW4T

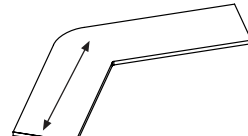

EVW6T

Base Storage (Metal)

Pedestals - Worksurface Supporting

Specify a pedestal bracket to attach worksurface supporting pedestals to panels. Worksurface must match the depth of the pedestal.

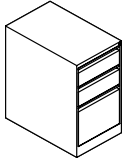

Box/Box/File
27.65"H x 15"W
18", 23", 24", 29", 30"D

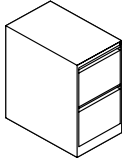

File/File
27.65"H x 15"W
18", 23", 24", 29", 30"D

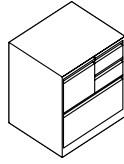

Combination Pedestal
(Handedness is determined by the side of the box drawer)
27.65"H x 30"W x 18"D

Pedestals - Mobile with Optional Cushion (specified separate)

Specified Separate

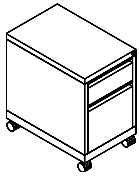

Box/File 60mm Caster
27.875"H x 15"W
18", 23", 29"D

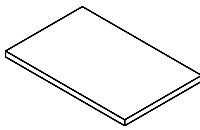

1" or 2" Thick Cushion
15"W
18", 23", 29"D

Base Storage (Metal)

1.5H Storage

21.75"H for overlapping surfaces (see also double wall storage cabinets)

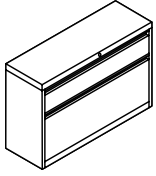

Lateral File
21.75"H x 18"D
30", 36", 42"W

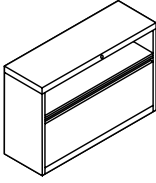

Lateral File with Top Open
21.75"H x 18"D
30", 36", 42"W

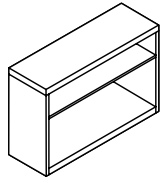

Bookcase
21.75"H x 18"D
30", 36", 42"W

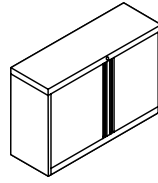

Storage Cabinet
21.75"H x 18"D
30", 36", 42"W

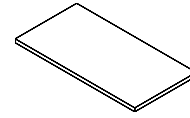

1" or 2" Thick Cushion
18"D
30", 36", 42"W

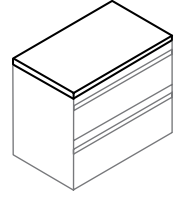

Lateral File Top
18"D
30", 36", 42"W

Lateral Files



2H
27.75"H x 18"D
30", 36", 42"W

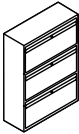

3H
40.5"H x 18"D
30", 36", 42"W

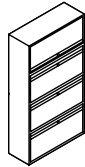

4H
54"H x 18"D
30", 36", 42"W



5H
65.88"H x 18"D
30", 36", 42"W

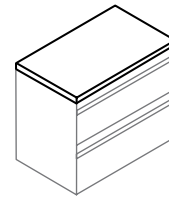

Lateral File Top
18"D
30", 36", 42"W

Storage Cabinets

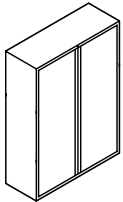

2H
27.75"H x 18"D
30", 36", 42"W

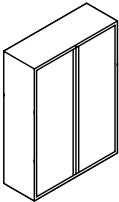

3H
40.5"H x 18"D
30", 36", 42"W

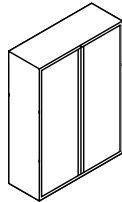

4H
54"H x 18"D
30", 36", 42"W

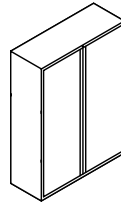

5H
65.88"H x 18"D
30", 36", 42"W

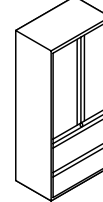

4H & 5H
Optional 2 or 3 Lateral File Drawers
18"D
30", 36", 42"W

Bookcases

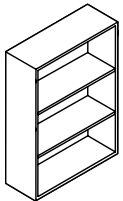

2H
1 Adjustable Shelf
27.75 x 18"D
30", 36", 42"W

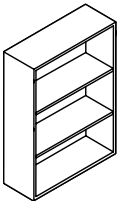

3H
2 Adjustable Shelves
40.5 x 18"D
30", 36", 42"W

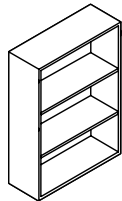

4H
3 Adjustable Shelves
54 x 18"D
30", 36", 42"W

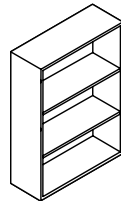

5H
4 Adjustable Shelf
65.88" x 18"D
30", 36", 42"W

Base Storage (Metal)

Towers

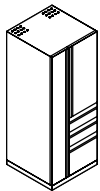

Box/Box/File Tower

Ventilation holes on top over wardrobe and shelving
24"D x 24"W
42", 50", 54, 66"H

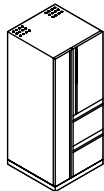

File/File Tower

Ventilation holes on top over wardrobe and shelving
24"D x 24"W
42", 50", 54, 66"H

Towers - Side Storage

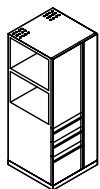

Box/Box/File Tower

Ventilation holes on top over wardrobe and shelving
24"D x 24"W
50", 54, 66"H

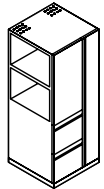

File/File Tower

Ventilation holes on top over wardrobe and shelving
24"D x 24"W
50", 54, 66"H

Double Wall - Sliding Glass (Frosted) Doors Double Wall, Leg Supported

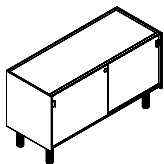

Single Cabinet

Freestanding - 4 legs
(round or square)
15"D x 21" or 28"H
30", 36", 42", 48", 54",
60"W

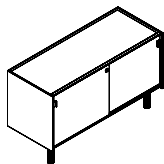

Single Cabinet

Panel Mount - 2 legs
(round or square)
15"D x 21" or 28"H
30", 36", 42", 48", 54",
60"W

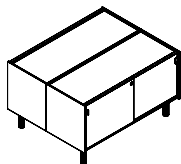

Double Cabinet (Back To Back)

Freestanding - 4 legs
(round or square)
15"D x 21" or 28"H
30", 36", 42", 48", 54",
60"W

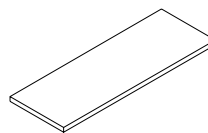

Cabinet Tops

15"D
30", 36", 42", 48", 54",
60"W

Overhead Storage (Metal)

Shelves – Panel Mounted/Wall Mounted Via Wall Tracks*

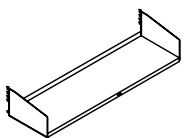

Low Profile Shelf

12"D
24", 30", 36", 42", 48", 54",
60"W

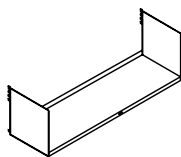

High Profile Shelf

12"D x 14.5"H
24", 30", 36", 42", 48", 54",
60"W

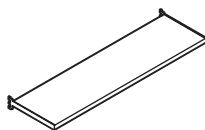

Laminated Shelf

8.5"D
18", 24", 30", 36", 42", 48"W

Overhead Cabinets – Panel Mounted/Wall Mounted Via Vertical Wall Tracks*

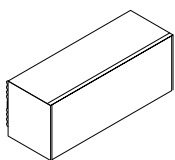

Flipper Door – Flat Front

Door flips above cabinet
14.5"H x 12"D
24", 30", 36", 42", 48", 54", 60"W
Specify lock separate.
Inside Dimensions – 12"H x 11.75"D
Optional whiteboard for door front specified separate

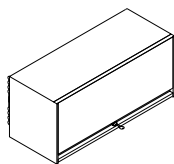

Flipper Door – Full Pull Front

Door flips above cabinet
16"H x 14.5"D
24", 30", 36", 42", 48", 54", 60"W
Lock included
Inside Dimensions – 12"H x 11.75"D

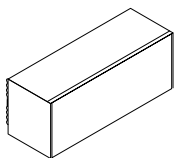

Flipper Door – Flat Front 17"H

Door flips above cabinet
17"H x 12"D
24", 30", 36", 42", 48"W
Specify lock separate.
Inside Dimensions – 15"H x 13"D

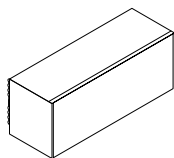

Flipper Door – Flat Front 17.5"H

Door flips above cabinet
17.5"H x 16"D
24", 30", 36", 42", 48", 54", 60"W
Lock included
Inside Dimensions – 14"H x 14.75"D
Ships fully assembled. Standard spring mounted task lights
cannot be specified, screw or magnetic mount lights only.

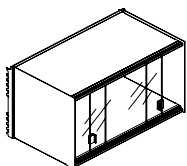

Sliding Glass Doors (Frosted Glass)

Available with or without locks (different part codes)
14.5"H x 12"D
24", 30", 36", 42", 48", 54" 60"W
Inside Dimensions – 12"H x 12"D
Glass – 6mm thick.
Tracks for sliding glass in Tungsten finish only.

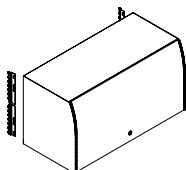

Easy Up Overhead (White Acrylic Front, Metal Case)

14.5"H x 12"D
30", 36", 42", 48", 54" 60"W
Lock included
Inside Dimensions – 14.25"H x 12"D
Meets CSA B651 Barrier Free Design & ADA

Overhead Storage (Metal)

Overhead Cabinets (Double Wall) – Panel Mounted/Wall Mounted Via Horizontal Bars or Vertical Wall Tracks

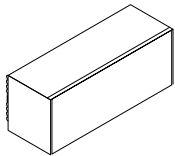

Double Wall Flipper Door Full Pull Front

Door flips above cabinet
15.4"H x 14.7"D
30", 36", 42", 48", 54" 60"W
Lock included
Inside Dimensions – 13"H x 13"D

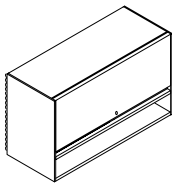

Double Wall Flipper Door With Shelf – Full Pull Front

Door flips above cabinet
22.4"H x 14.7"D
30", 36", 42", 48", 54" 60"W
Lock included
Inside Dimensions – 13"H x 13"D

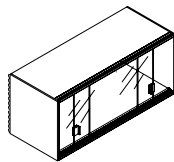

Double Wall Sliding Glass

Available with or without locks
(different part codes)
15.4"H x 14.7"D
30", 36", 42", 48", 54" 60"W
Lock included
Inside Dimensions – 12"H x 12"D

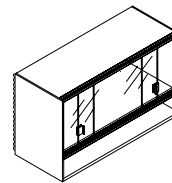

Double Wall Sliding Glass with Shelf

Available with or without locks
(different part codes)
22.4"H x 14.7"D
30", 36", 42", 48", 54" 60"W
Lock included
Inside Dimensions – 12"H x 12"D

Center Panel Mount

Specify panel mounting brackets separate

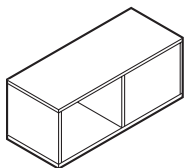

Dual Access Open

All Laminate
15"H x 14.125"D
36", 42", 48", 54" 60"W
Inside Dimensions – 13"H x 13"D
each side
Panel mount brackets specified
separate

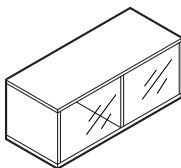

Dual Access Sliding Glass

Laminate sides and center divider,
metal top and bottom
15"H x 14.125"D
36", 42", 48", 54" 60"W
Inside Dimensions – 13"H x 13"D
each side
Panel mount brackets specified
separate
Glass tracks in Tungsten only
Ships KD
Lock Option not available

*Horizontal Bars (JBAR) (EVSHJB _ _) specify one set per overhead (for double wall only).

*Vertical Wall Tracks (EVHV01) ships in pairs, (2) overheads can share (1) track.



Base Storage (Laminate)

Pedestal - Worksurface Supporting

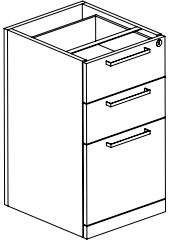

**Box/Box/File
Worksurface Supporting
Pedestal**

28"H X 15.5"D
18", 23", 29"W

*Cannot Use Pedestal Bracket

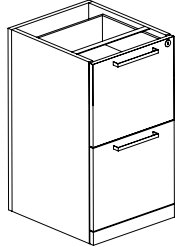

**File/File
Worksurface Supporting
Pedestal**

28"H X 15.5"D
18", 23", 29"W

*Cannot Use Pedestal Bracket

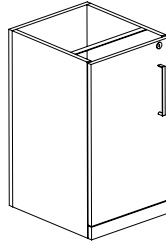

**1 Door
Worksurface Supporting
Pedestal**

28"H X 15.5"D
18", 23", 29"W

*Cannot Use Pedestal Bracket

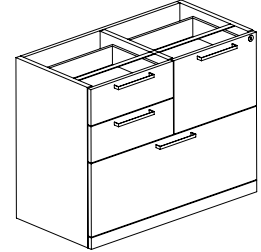

**Combo Lateral File
Worksurface Supporting
Pedestal**

28"H
18", 22"W
30", 36"D

Pedestals - Mobile

Specify panel mounting brackets separate

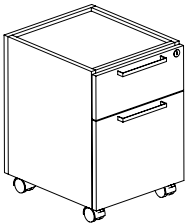

**Box/File
Mobile Pedestal
W/Inset Top**

22.69"H X 15.5"D
20", 24"W

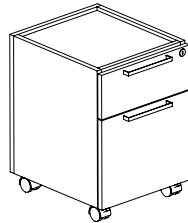

**Box/File
Mobile Pedestal
W/Inset Top**

28"H X 15.5"D
18", 23"W

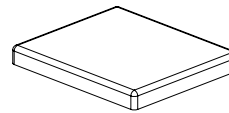

Cushion (For B/F W/Inset Top Only)

2" Thick X 15.5"D
18", 24"W

Credenzas

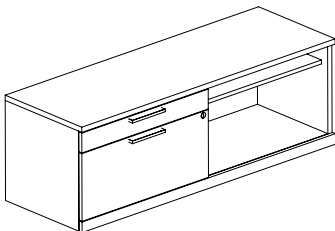

**Box/File Open
Credenza, 20"H**

20"H X 20"D
48", 54", 60", 66", 72"W

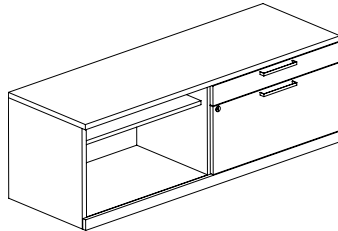

**Open/Box/File
Credenza, 20"H**

20"H X 20"D
48", 54", 60", 66", 72"W

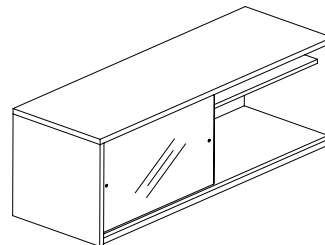

**Sliding Glass Door
Credenza, 20"H**

20"H X 20"D
48", 60", 72"W

Lateral Files

Lateral File

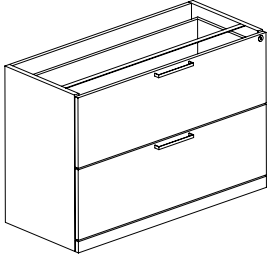

File/File
Worksurface Supporting Lateral File
28"H X 18"W
30", 36", 42"D

Storage Cabinet

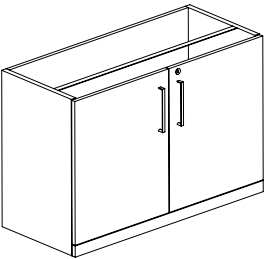

2-Door
Worksurface Supporting Lateral File
28"H
18", 22"W
30", 36", 42"D

Towers

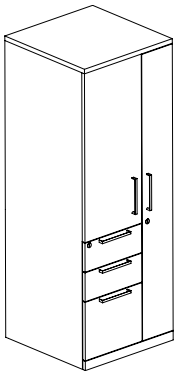

Box/Box/File
Storage Tower W/Wardrobe and Shelving
24"W X 24"D
42", 48," 54", 66"W

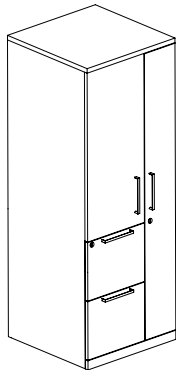

File/File
Storage Tower W/Wardrobe and Shelving
24"W X 24"D
42", 48," 54", 66"W

Tower -Side Storage

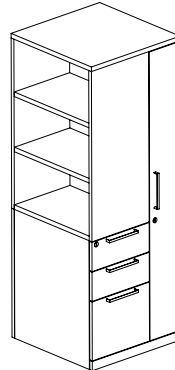

Box/Box/File
Storage Tower W/Side Access
24"W X 24"D
42", 48," 54", 66"W

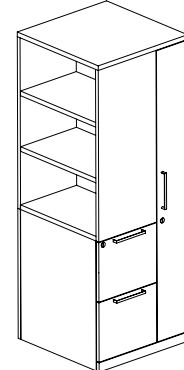

File/File
Storage Tower W/Side Access
24"W X 24"D
42", 48," 54", 66"W

showrooms and distribution centers throughout the united states

SHOWROOMS

Atlanta
10 10th Street, Suite 150
Atlanta, GA 30309
T 404.879.0998
F 404.879.9995

Chicago
The Merchandise Mart
10th Floor, Suite 1035
Chicago, IL 60654
T 312.755.0843
F 312.755.0837

Ft. Lauderdale
Las Olas City Centre
401 East Las Olas Blvd.,
Suite 230
Ft. Lauderdale, FL 33301
T 954.763.2684
F 954.763.6870

Philadelphia Area
119 Greentree Road
Marlton, NJ 08053
T 856.596.3390
F 856.596.4472

St. Louis
5 Document Drive
St. Louis, MO 63114
T 314.432.4463
F 314.432.4471

Boston
One Harbor Street,
Suite 104
Boston, MA 02210
T 617.406.5435
F 617.406.5438

Detroit Area
25925 Telegraph Road
Suite 145
Southfield, MI 48034
T 248.357.7211
F 248.357.7241

New York City
386 Park Avenue South,
7th floor
New York, NY 10016
T 212.545.9900
F 212.545.5826

Phoenix
4675 East Cotton
Center Boulevard,
Suite 165
Phoenix, AZ 85040
T 602.426.0666
F 602.426.1148

Washington, DC
1130 Connecticut
Avenue
Washington, DC 20036
T 202.659.0230
F 202.659.0306

SHOWROOMS + DISTRIBUTION CENTERS

Atlanta Area
2124 Evergreen Blvd.
Duluth, GA 30096
T 678.602.4130
F 678.602.4136

Chicago Area
1879 Internationale Blvd.
Glendale Heights, IL
60139
T 630.681.2818
F 630.681.1631

Denver Area
16401 E. 33rd Dr., Ste. 50
Aurora, CO 80011
T 303.340.1617
F 303.340.1657

Los Angeles Area
12320 Bloomfield
Avenue, Unit A
Santa Fe Springs, CA
90670
T 562.484.9686
F 562.484.9685

Pittsburgh Area
380 Leetsdale
Industrial Dr.
Leetsdale, PA 15056
T 724.385.1200
F 724.385.1207

Seattle Area
Oakesdale Commerce
Center
820 Southwest 34th St.
Building W7, Suite A
Renton, WA 98057
T 425.291.9282
F 425.291.9287

Baltimore Area
Troy Hill Corporate
Center
7030 Troy Hill Drive
Elkridge, MD 21075
T 410.379.8021
F 301.362.9444

Cincinnati Area
8712 LeSaint Drive
Fairfield, OH 45014
T 513.777.0009
F 513.777.5863

Ft. Lauderdale Area
560 Sawgrass
Corporate Parkway
Sunrise, FL 33325
T 954.846.8888
F 954.846.8110

Minneapolis Area
2000 Freeway
Boulevard
Brooklyn Center, MN
55430
T 763.560.8196
F 763.560.2098

San Antonio Area
6950 Alamo Downs
Parkway, Suite 100
San Antonio, TX 78238
T 210.684.8450
F 210.684.3700

Kansas Area
11617 West 81st Street
Lenexa, KS 66214
T 913.310.9963
F 913.310.9976

Boston Area
19 Connector Rd., Unit 1
Andover, MA 01810
T 978.470.8463
F 978.470.8920

Dallas Area
2025 W. Beltline Rd.,
#100
Carrollton, TX 75006
T 972.236.1366
F 972.236.1372

Houston
7865 Northcourt Road,
Building D, Suite 200
Houston, TX 77040
T 713.695.5777
F 713.695.5778

New Orleans Area
901 South Labarre
Road, Suite 201
Metairie, LA 70001
T 504.834.6228
F 504.835.9638

San Francisco Area
44091 Nobel Drive
Fremont, CA 94538
T 510.897.4150
F 510.897.4156

Tampa Area
10351 Windhorst Road
Tampa, FL 33619
T 813.621.6272
F 813.621.7958



Global - USA Headquarters
17 West Stow Road P.O. Box 562
Marlton, New Jersey U.S.A. 08053
Tel (856) 596-3390 (800) 220-1900
Fax (856) 596-5684
www.globalfurnituregroup.com

Global - Canada Headquarters
1350 Flint Road
Downsview, ON Canada M3J 2J7
Sales & Marketing: Tel (1-877) 446-2251
Customer Service: Fax (800) 361-3182
Government Customer Service: Fax (416) 739-6319

